



CATALOGUE

— LIFTING EQUIPMENT





DIMET GmbH is one of the leading producers of lifting magnets with headquarter in Germany and sales network worldwide.

Established in 2000 as an engineering company, DIMET has developed into a modern high-technology enterprise with extensive production and designing capabilities, offering wide range of solutions for cargo lifting and material handling.

We design and manufacture wide range of lifting electromagnets, electro-permanent lifting magnets, electromagnetic spreader beams, iron separators, control systems, grab buckets and a wide range of lifting equipment.

CE confirmed. The company's management system satisfies ISO 9001 requirements.

So whenever your company needs a solution for scrap processing, coil, rail, slab or any other material handling, we will find the best possible one for you.

OUR ADVANTAGES

- High-qualified personnel
- Strong R&D capability and engineering excellence
- Own inventions, some of them are patented
- High-quality pre-sales & after-sales technical services

CONTENTS

01. LIFTING MAGNETS



- 06 EMG-SM and EMG-HC SERIES Scrap handling magnets
- 08 **Lifting beam with scrap handler**
- 09 **SG Unified lifting system**
- 10 EMGS SERIES (for reloading of sheet steel in pieces)
EMGS SERIES (for reloading of sheet steel in packs)
- 12 EMGS SERIES (for reloading of square and round blanks)
EMGS SERIES (for reloading of packs of rebars, tubes,
long steel products)
- 14 EMGK SERIES Electromagnets for wire coils
- 16 EMGP SERIES Electromagnets for long products
- 18 EMG SCRAP-B SERIES Rectangular scrap magnets
- 20 EMG SCRAP-Z SERIES Scrap magnets
- 22 EMG SLAB-T SERIES Round electromagnets for handling
of slabs
- 24 EMGM SERIES for mild slab turning
- 26 EMG SERIES Rectangular electromagnets for handling
of blooms, rails, forgings
- 28 EMGR SERIES Electromagnets for vertical coils
- 30 EMGB SERIES Electromagnets for horizontal coils
- 32 EMGT SERIES Electromagnets for large diameter tubes



02. ELECTROPERMANENT

- 34 IMG SERIES Electropermanent magnets (steel sheets
and slabs)

03. LIFTING BEAMS



- 36 Magnetic beam for square blanks
- 37 Magnetic beam for round blanks
- 38 Magnetic beam for handling wire coils
- 39 Rotary extendable magnetic beam for long loads
- 40 Magnetic beam for handling slabs
- 41 Magnetic beam for mild slab turning
- 42 Spatial beam for handling mill rolls
- 43 Hook linear beam

04. ORANGE PEEL GRAPPLES



- 44 DIMET DS 4- and 5-tine grapples
- 46 DIMET DSB hydraulic grapples

05. GRAPPLES



- 48 Two or multiple tine rope grapples
- 49 Motorized two or multiple tine grapples

06. SEPARATORS



- 50 Suspended iron separators
- 52 Self-unloaded iron separators

07. CONTROL SYSTEMS



- 54 PN-500 SERIES Electromagnet control systems voltage converter
- 55 Uninterrupted power supplies for electromagnets
- 56 PN-500-G SERIES Electromagnet control system of voltage converter

LIFTING ELECTROMAGNETS



CAST CASE

Provides reliable protection and fast cooling of the electromagnet.

MATERIAL

High quality wire reduces possibility of turn-to-turn short circuit and ensures high reparability.

HIGH-QUALITY SEALING COMPOUND

Efficiently dissipates heat from the coil and ensures high electrical insulation.

HEAVY-DUTY STEEL BOTTOM PLATE

Protects the coil and significantly increases electromagnet service life.

HEAT INSULATION GASKET

Provides additional coil protection during operations with hot loads up to 650 °C / 1200 °F and guarantees stability of lifting parameters (extra optional).

KEY FEATURES OF DIMET ELECTROMAGNETS



Increase in labor efficiency due to the stability of load-lifting parameters while in operation.



The reduction of equipment costs due to long life of the magnet and long-term maintainability of the coil.



May be used with any up-to-date machinery due to the universal mounting and connection system.



Energy saving due to up-to-date energy-efficient solutions in the electromagnet design.



We conserve the planet saves resources by reusing the materials used in production.

TRANSPORTED CARGO

- Scrap
- Turnings
- Metal charge

COMPATIBLE EQUIPMENT

- Mobile material handlers
- Overhead cranes
- Portal cranes
- Gantry cranes
- Railway cranes

KEY FEATURES

- Long continuous operating period
- Special design for operation in underwater conditions as an option
- Heat-resistant version (cargo temperature up to 650 °C/1200 °F) as an option

WINDING TYPE

- Aluminium coil

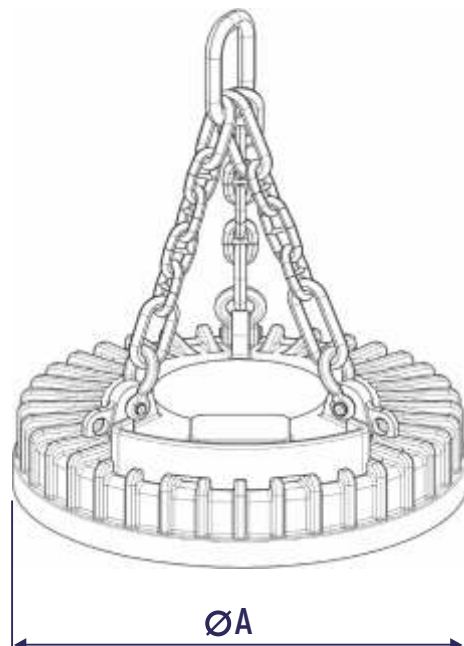

EMG-SM SERIES (lightweight scrap, steel turnings)

Model	Pull-off force kg/lbs, at least	Generator power, W	Weight, kg/lbs	Rated current, A	Rated power, W	Diameter ØA, mm/in	Lifting capacity, kg/lbs				
							Plates	Pig Iron	Steel turnings	Light scrap	Heavy scrap
EMG 085SM	12000/26460	5000	700/1550	18	3900	850/34	6000/13200	460/1010	180/400	230/510	350/772
EMG 105SM	17000/37480	7500	860/1900	25	5500	1050/41	8500/18700	540/1120	220/485	290/640	460/1010
EMG 115SM	22000/48500	10000	1120/2470	31	6820	1150/45	11000/24200	700/1540	290/640	380/838	610/1345
EMG 125SM	26000/57320	10000	1400/3100	39	8580	1250/49	13000/28600	870/1920	350/772	540/1200	850/1900
EMG 135SM	30000/66140	15000	1750/3850	46	10120	1350/53	15000/33000	1020/2250	410/904	620/1370	1030/2300
EMG 145SM	36000/79370	15000	2150/4750	52	11440	1450/57	18000/39600	1200/2650	480/1060	790/1742	1230/2700
EMG 155SM	40000/88180	15000	2700/5950	61	13400	1550/61	20000/44000	1480/3300	600/1323	1000/2200	1510/3330
EMG 170SM	55000/121250	20000	3230/7100	72	15840	1700/67	27500/60500	1800/3970	710/1600	1180/2600	1740/3840
EMG 185SM	66000/145500	25000	4000/8830	85	18700	1850/73	33000/72750	2200/4850	840/1850	1440/3200	2190/4830
EMG 200SM	75000/165350	25000	4800/10600	105	23100	2000/79	37500/82670	2610/5800	990/2200	1670/3700	2670/5900

EMG-HC series (heavy scrap, bundles, steel turnings)

Model	Pull-off force kg/lbs, at least	Weight, kg/lbs	Rated current, A	Rated power, W	Diameter ØA, mm/in	Lifting capacity, kg/lbs				
						Plates	Pig Iron	Steel turnings	Light scrap	Heavy scrap
EMG 125HC	40000/88180	2100/4630	50	11000	1250/49	20000/44100	1300/2900	510/1100	800/1800	1250/2800
EMG 145HC	56000/123460	3500/7720	65	14300	1450/57	28000/62000	2050/4600	800/1800	1280/3000	2000/4410
EMG 170HC	74000/163140	5500/12130	85	18700	1700/67	37000/82000	3080/6800	1220/2700	2000/4400	2950/6500
EMG 185HC	110000/242510	7700/16976	100	22000	1850/73	55000/99200	4550/10000	1700/3850	3000/6600	4480/10000
EMG 210HC	130000/286600	10200/22500	114	25000	2100/83	65000/14330	5700/12600	2300/5100	3800/8400	5600/12350
EMG 230HC	180000/396830	14500/32000	155	34100	2300/90	90000/200000	8000/17600	3150/7000	6600/15000	7900/17420

08 Lifting beam with scrap handler

APPLICATION

- Used for gripping the magnet by the handler's grapple

COMPATIBLE EQUIPMENT

- Mobile material handlers

KEY FEATURES

- Lifting beams can be tailor-made according to the customer's requirements
- Easy to use, reduced time expenses, and improved manufacturing productivity



Model	Lifting capacity, t/lbs	Compatible electromagnets	Weight, kg/lbs
PG 10-SM-SE	10/22050	EMG 105SM	200/440
		EMG 115SM	
		EMG 125SM	
PG 16-SM-SE	16/35300	EMG 135SM	260/570
		EMG 145SM	
		EMG 155SM	
		EMG 170SM	

APPLICATION

- Module for reloading, grabbing and sorting of scrap and steel

COMPLETE SET

- SM SERIES Electromagnet
- DYNASET Generator

KEY FEATURES

- Easy installation and possibility to quick change during operation



Model	Electromagnet	Generator power, W	Rated power, W	Weight, kg/lbs	Lifting capacity, kg/lbs				
					Plates	Pig Iron	Steel turnings	Light scrap	Heavy scrap
SG 085SM-DNS06	EMG 085SM	6000	3900	1250/2760	6000/13200	460/1010	140/310	230/510	350/772
SG 105SM-DNS06	EMG 105SM	6000	5500	1410/3110	8500/18700	540/1120	170/375	290/640	460/1010
SG 115SM-DNS10	EMG 115SM	10000	6800	1870/4123	11000/24200	700/1540	270/595	380/838	610/1345
SG 125SM-DNS10	EMG 125SM	10000	8600	2150/4740	13000/28600	870/1920	350/772	540/1200	850/1900
SG 135SM-DNS12	EMG 135SM	12000	10100	2550/5600	15000/33000	1020/2250	410/904	620/1370	1030/2300
SG 145SM-DNS12	EMG 145SM	12000	11400	2950/6500	18000/39600	1200/2650	480/1060	790/1742	1230/2700

This system can be developed for any DIMET electromagnet

TRANSPORTED CARGO

- Slabs
- Sheet steel in packs or in single pieces
- Tubes in packs

COMPATIBLE EQUIPMENT

- Cranes
- Spreader beams

KEY FEATURES

- High reliability and durability of the winding
- High stability of lifting operations
- Special design for use in underwater conditions as an option
- Heat-resistant version (cargo temperature up to 650 °C/1200 °F) as an option

WINDING TYPE

- Aluminium coil



EMGS SERIES (for reloading of sheet steel in pieces)

Model	Voltage, V	Current, A	Rated power, W	Weight, kg/lbs	Pull-off force, kg/lbs	Lifting capacity for plates, kg/lbs	Lifting capacity for sheets, kg/lbs
EMGS 055-30-33/A-U1	220	3,6	800	180/400	2000/4400	1000/2200	700/1500
EMGS 060-40-32/A-U1	220	11,8	2600	360/800	5000/11000	2500/5500	1700/3700
EMGS 100-34-37/A-U1	220	12,5	2750	480/1100	9000/19800	4500/9900	2300/5100
EMGS 110-34-35/A-U1	220	11	2400	460/1000	8000/17600	4000/8800	2000/4400
EMGS 120-34-36/A-U1	220	11	2400	700/1550	12000/26500	6000/13200	3500/7700
EMGS 185-38-38/A-U1	220	20	4400	850/1900	13000/28700	6500/14300	4000/8800
EMGS 200-38-36/A-U1	220	20	4400	900/2000	15000/33100	7500/16550	5000/11000
EMGS 220-38-36/A-U1	220	20	4400	1000/2200	15000/33100	7500/16550	5000/11000
EMGS 270-36-37/A-U1	220	15	3300	1200/2650	20000/44150	10000/22000	6000/13200

EMGS SERIES (for reloading of sheet steel in packs)

Model	Voltage, V	Current, A	Rated power, W	Weight, kg/lbs	Pull-off force, kg/lbs	Lifting capacity for plates, kg/lbs	Lifting capacity for pack of sheets, kg/lbs
EMGS 080-54-40/A-U1	220	16	3500	700/1550	10000/22100	5000/11000	1500/3300
EMGS 100-60-44/A-U1	220	20	4400	1050/2200	20000/44200	10000/22100	2000/4400
EMGS 110-60-50/A-U1	220	19	4200	1350/3000	25000/55200	12500/27600	2700/6000
EMGS 120-64-46/A-U1	220	30	6600	1550/3400	30000/66200	15000/33100	3500/7700
EMGS 140-70-48/A-U1	220	40	8800	2200/4900	40000/88300	20000/44150	5000/11000
EMGS 160-76-54/A-U1	220	50	11000	3000/6600	60000/132450	30000/66200	7500/16500

TRANSPORTED CARGO

- Round metal blanks
- Rectangular metal blanks
- Blooms and rails
- Tubes in packs
- Rebars in packs

COMPATIBLE EQUIPMENT

- Cranes
- Spreader beams

KEY FEATURES

- High reliability and durability of the winding
- High stability of lifting operations
- Special design for use in underwater conditions as an option
- Heat-resistant version (cargo temperature up to 650 °C/1200 °F) as an option

WINDING TYPE

- Aluminium coil



EMGS SERIES (for reloading of square and round blanks)

Model	Voltage, V	Current, A	Rated power, W	Weight, kg/lbs	Pull-off force, kg/lbs	Lifting capacity, kg/lbs				
						Plates	Square blanks	Hot square blanks 500 °C/932 °F	Round blanks	Hot round blanks 500 °C/932 °F
EMGS 110-60-50/AT-U1	220	19	4200	1350/3000	25000/55200	12500/27600	10000/22100	7500/16550	-	-
EMGS 110-69-52/AT-U1	220	20	4400	1600/3550	28000/61800	14000/30900	12000/20500	9000/19900	9500/15500	7000/15500
EMGS 120-76-52/AT-U1	220	30	6600	2000/4400	40000/88300	20000/44150	18000/39800	15000/33000	13000/24300	11000/24300
EMGS 130-75-52/AT-U1	220	30	6600	2400/5300	48000/106000	24000/53000	22000/48600	17000/37500	14000/26500	12000/26500
EMGS 135-71-51/AT-U1	220	25	5500	1900/4200	30000/66200	15000/33000	14000/30900	9000/19900	10000/16600	7500/16600
EMGS 140-97-63/AT-U1	220	34	7500	3400/4200	60000/132500	30000/66200	26000/57400	19500/43000	15000/25400	11500/25400
EMGS 145-66-49/AT-U1	220	34	7500	2300/5100	50000/110400	25000/55200	22000/48600	17000/37500	14000/26500	12000/26500

EMGS SERIES (for reloading of packs of rebars, tubes, long steel products)

Model	Voltage Current, V	Current, A	Rated power, W	Weight, kg/lbs	Lifting capacity, kg/lbs		
					Packs of rebars	Packs of sections	Packs of pipes
EMGS 070-74-48/A-U1	220	17	3750	1050/2300	4500/9930	3500/7730	3000/6630
EMGS 110-86-45/A-U1	220	28	6200	1600/3500	5000/11040	4500/9930	4000/8830
EMGS 120-86-48/A-U1	220	30	6600	2000/4400	6000/13300	5000/11040	4500/9930
EMGS 140-80-48/A-U1	220	40	8800	2150/4750	8000/17660	6000/13250	5000/11040



TRANSPORTED CARGO

- Wire coils

COMPATIBLE EQUIPMENT

- Cranes
- Spreader beams

KEY FEATURES

- High reliability and durability of the winding
- High stability of lifting operations
- Special design for use in underwater conditions as an option
- Heat-resistant version (cargo temperature up to 650 °C/1200 °F) as an option

WINDING TYPE

- Aluminium coil

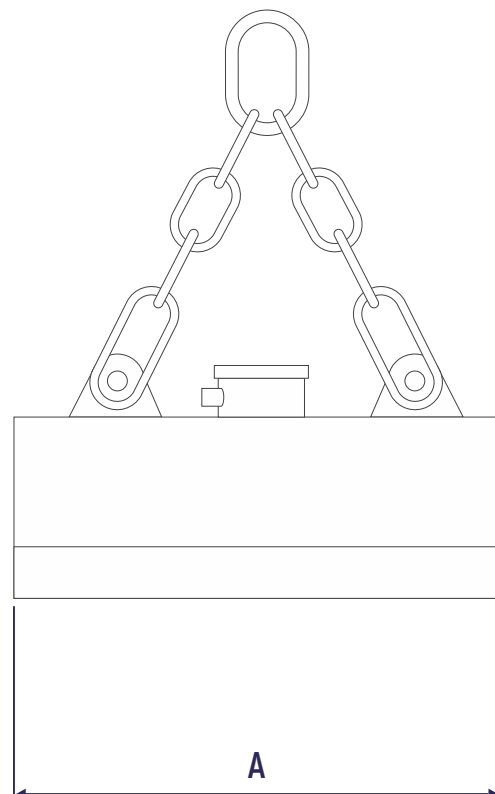

EMGK SERIES (for lifting of wire coils)

Parameters	EMGK 105-70-54/ A-U1	EMGK 110-67-54/ A-U1	EMGK 120-65-52/ A-U1	EMGK 130-65-54/ A-U1	EMGK 140-65-52/ A-U1	EMGK 160-65-54/ A-U1	EMGK 180-65-51/ A-U1
Rated voltage, V	220	220	220	220	220	220	220
Rated current at 20 °C /70 °F, A	25	28	28	30	30	35	32
Rated power, kW	5,5	6,2	6,2	6,6	6,6	7,7	7,7
Bundle outside full diameter, mm/in	1250/49	1250/49	1250/49	1250/49	1250/49	1250/49	1250/49
Lifting capacity at most, kg/lbs	4000/8830	4500/9930	4500/9930	5000/11030	5500/12150	6300/13900	6500/14350
Bundle height at most, mm/in	1100/43	1200/47	1300/51	1400/55	1500/59	1700/67	1900/74
Dimensions AxBxC, mm/in	1050x690x540/ 41x27x21	1100x670x540/ 43x26x21	1200x670x520/ 47x25x20	1300x650x540/ 51x25x21	1400x650x520/ 55x25x20	1600x650x540/ 63x25x21	1800x650x510/ 70x25x20
Weight, kg/lbs	1380/3050	1550/3400	1650/3640	1800/3970	1900/4200	2200/4860	2400/5300

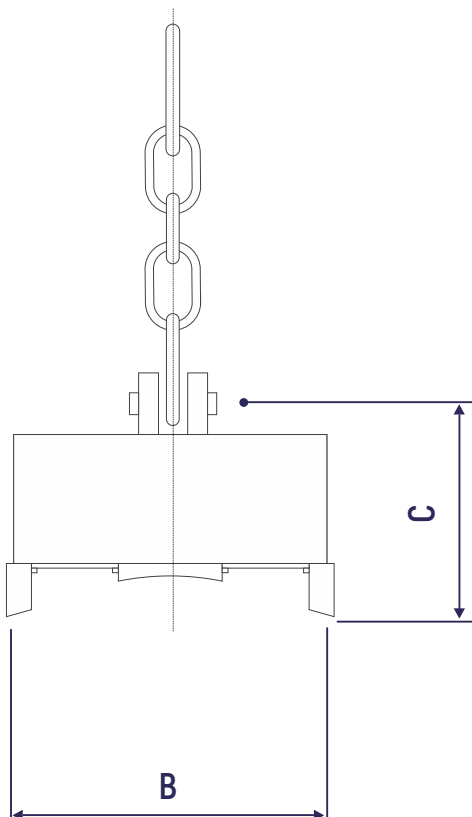

TRANSPORTED CARGO

- Long rolled steel
- Packs of tube blanks, circle, pipes

COMPATIBLE EQUIPMENT

- Cranes
- Spreader beams

KEY FEATURES

- High reliability and durability of the winding
- Energy saving as per ton of the transported cargo
- Special design for operation in underwater conditions as an option
- Heat-resistant version (cargo temperature up to 650 °C/1200 °F) as an option

WINDING TYPE

- Aluminium coil

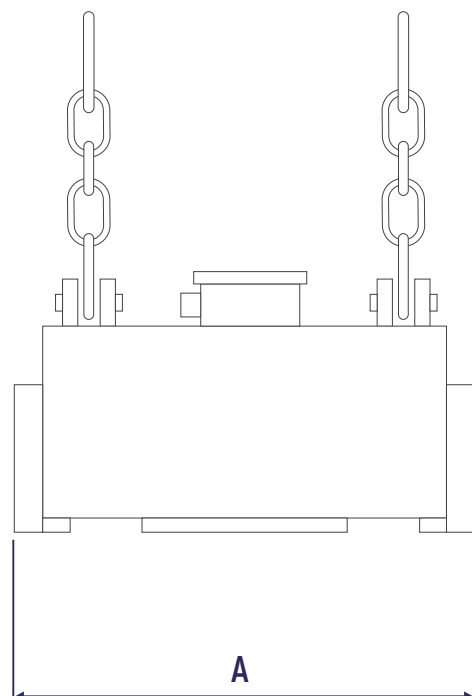

EMGP SERIES (for long rolled products in packs)

Parameters	EMGP 088-62-51/A-U1	EMGP 090-65-57/A-U1	EMGP 110-68-60/A-U1
Rated voltage, V	220	220	220
Rated current at 20 °C/70 °F, A	20	22	27
Rated power, W	4400	4800	6000
Lifting capacity for pack of rolled products, kg/lbs	2000/4400	3000/6600	6000/13300
Lifting capacity for pack of rebars, kg/lbs	3000/6600	4000/8830	9000/19900
Lifting capacity for circle Ø 400-600 mm, kg/15-23 in, lbs	6000/13300	10000/22100	16000/35320
Dimensions AxBxC, mm/in	880x620x510/34x24x20	910x650x570/35x25x22	1100x680x600/43x26x23
Weight, kg/lbs	1100/2430	1300/2900	1800/4000

EMGP SERIES (for circle)

Parameters	EMGP 112-88-56/A-U1	EMGP 160-110-65/A-U1
Rated voltage, V	220	220
Rated current at 20 °C/70 °F, A	28	41
Rated power, W	6200	9000
Lifting capacity for circle Ø 400-600 mm, kg/15-23 in, lbs	10000/22100	20000/44150
Dimensions AxBxC, mm/in	1120x880x560/44x34x22	1600x1100x650/63x43x25
Weight, kg/lbs	1800/4000	4900/10800

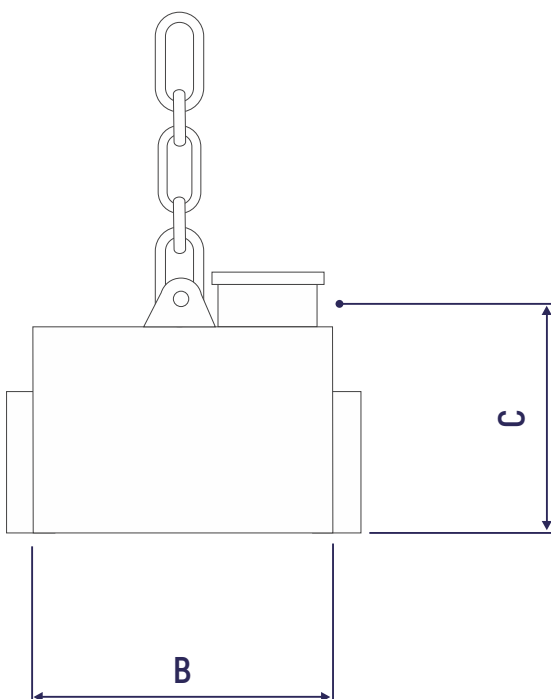

TRANSPORTED CARGO

- Scrap
- Turnings
- Metal charge

COMPATIBLE EQUIPMENT

- Overhead cranes
- Portal cranes
- Gantry cranes
- Railway cranes

KEY FEATURES

- Used for unloading of scrap out of the railcar
- High stability of lifting operations
- Special design for operation in underwater conditions as an option
- Heat-resistant version (cargo temperature up to 650 °C/1200 °F) as an option

WINDING TYPE

- Aluminium coil

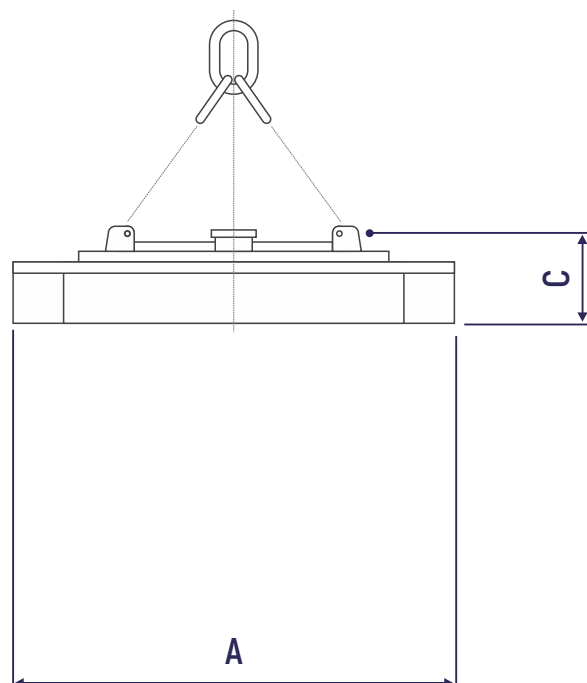

EMG SCRAP-B SERIES Rectangular scrap magnets

Parameters	EMG 230-150-50/A-U1	EMG 260-180-50/A-U1	EMG 300-200-52/A-U1	EMG 350-220-52/A-U1
Rated voltage, V	220	220	220	220
Rated electromagnet current at 20 °C/70 °F, A	105	140	180	220
Rated power, W	23100	30800	29600	48400
Pull-off force, kg/lbs	110000/24250	130000/290000	200000/441000	250000/551200
Dimensions AxBxC, mm/in	2300x1500x500/91x59x20	2600x1800x550/102x71x22	3000x2000x670/118x79x26	3500x2200x730/138x87x29
Weight, kg/lbs	5700/12600	8000/18000	14700/32410	20000/44100
Lifting capacity, kg/lbs				
Plates	50000/110200	65000/143490	100000/220500	125000/280000
Pig Iron	3300/7300	4500/9900	8800/19400	12400/27300
Light scrap/#1HM	2200/4850	3000/6600	5400/12000	7500/17000
Heavy scrap/#2HM	3500/7720	4400/9700	8600/19000	12000/26500

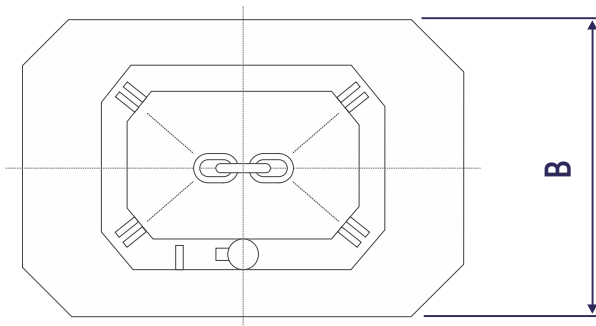

TRANSPORTED CARGO

- Scrap
- Turnings
- Metal charge

COMPATIBLE EQUIPMENT

- Mobile material handlers
- Overhead cranes
- Portal cranes
- Gantry cranes
- Railway cranes

KEY FEATURES

- Used for railcar cleaning
- Stability of lifting operations
- Special design for operation in underwater conditions as an option
- Heat-resistant version (cargo temperature up to 650 °C/1200 °F) as an option

WINDING TYPE

- Aluminium coil

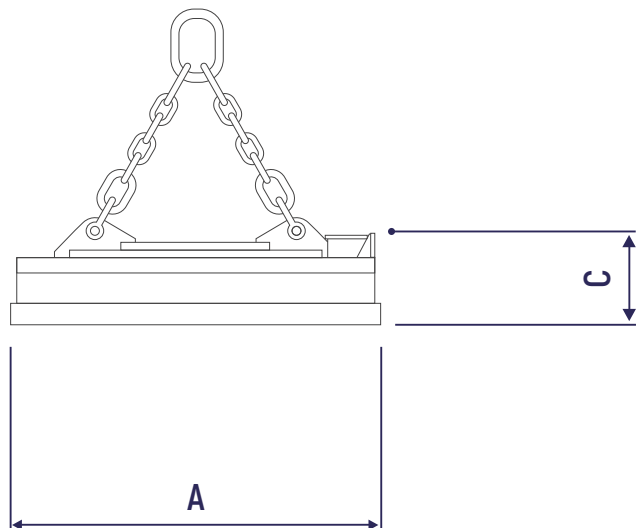

SCRAP-Z SERIES (for cleaning of wagons from scrap)

Parameters	EMG 120-120-32/A-U1	EMG 170-170-32/A-U1
Rated current at 20 °C/70 °F, A	45	52
Rated power, W	9900	11400
Steady-state power, W	6600	8800
Pull-out force, at least, kg/lbs	27000/55100	35000/77200
Dimensions AxBxC, mm/in	1200x1200x320/47x47x12	1700x1700x320/67x67x12
Weight, kg/lbs	1600/3500	2500/5100
Lifting capacity, kg/lbs		
Plates	13500/29762	17500/38600
Steel turnings	250/550	400/900
Pig Iron	850/1900	900/2000
Light scrap/#1HM	600/1300	700/1500
Heavy scrap/#2HM	850/1900	1000/2200

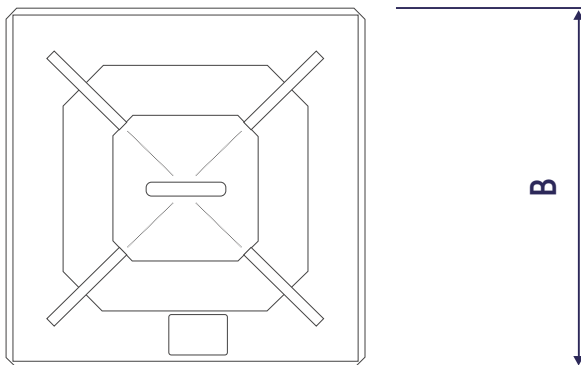

TRANSPORTED CARGO

- Slabs
- Forgings
- Heavy-weight metal blanks

COMPATIBLE EQUIPMENT

- Cranes
- Spreader beams

KEY FEATURES

- Energy saving as per ton of the transported cargo
- Heat-resistant version (cargo temperature up to 650 °C/1200 °F) as an option

WINDING TYPE

- Aluminium coil

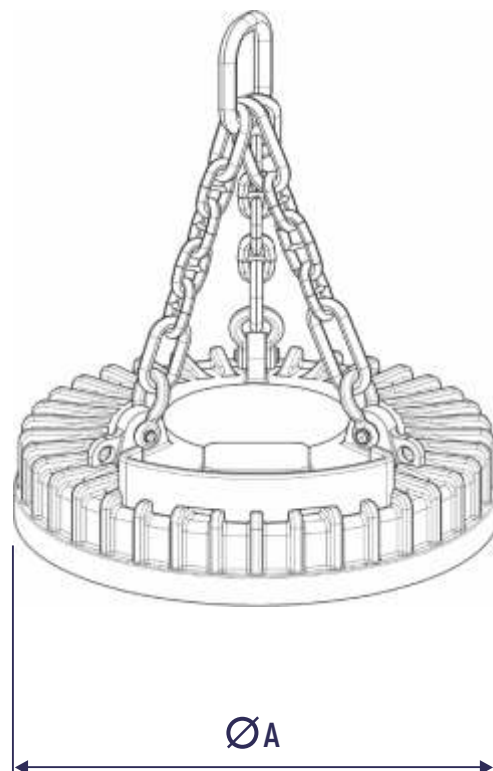

SLAB-T SERIES (handling of slabs, forgings)

Model	Pull-off force kg/lbs, at least	Rated power, W	Weight, kg/lbs	Rated current, A	Power with the heated coil, W	ØAxBxC, mm/in	Lifting capacity for slabs (kg/lbs) temperature kg current, A		
							200 °C/390 °F	400 °C/750 °F	600 °C/1110 °F
EMG 100ST/AT-U1	25000/55110	4800	1050/2310	22±8%	3400	1000x320x1100/39x12x43	12000/21600	11000/19800	9500/17100
EMG 120ST/AT-U1	35000/77200	8400	1550/3420	38±8%	5800	1200x320x1350/47x12x53	17000/30600	16000/29000	13500/24300
EMG 140ST/AT-U1	50000/110200	12800	2150/4740	58±8%	8900	1400x380x1400/55x15x55	24000/43200	22500/40500	19700/35500
EMG 160ST/AT-U1	70000/154300	15400	3700/8160	70±8%	10800	1600x540x1700/63x21x67	33500/60300	31800/57300	28000/50400
EMG 180ST/AT-U1	100000/220500	18000	5000/11000	82±8%	12700	1800x480x1650/71x19x65	48000/86400	45500/82000	40000/72000

SLAB-T SERIES HEAT-RESISTANT ELECTROMAGNETS

developed in special cast cases with extended poles for extremely heavy operating mode for high efficient handling of slabs, forgings, heavyweight metal blanks at steel mills, marine terminals and EPC companies, with the cargo temperature up to 650 °C/1200 °F.

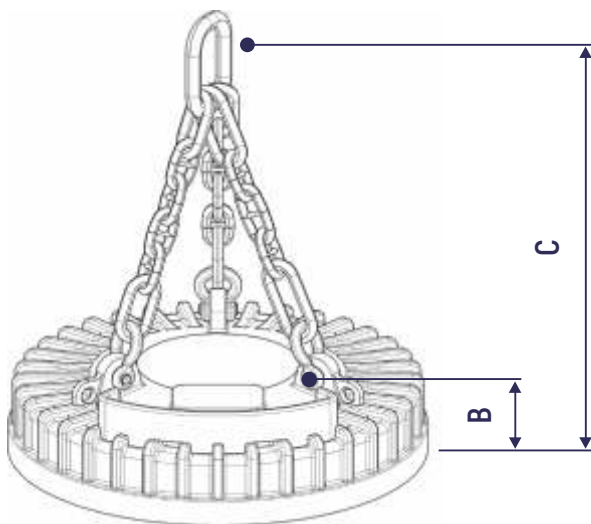

TRANSPORTED CARGO

- Slabs
- Compatible equipment
- Cranes
- Spreader beams

KEY FEATURES

- Special designed wear-resistant case for long-term operation
- Special magnet shape with pole for secure slabs turning

ADVANTAGES

- Fast slab turning
- Safety during operation
- Cost effective
- Low noise level during operation

WINDING TYPE

- Aluminium coil

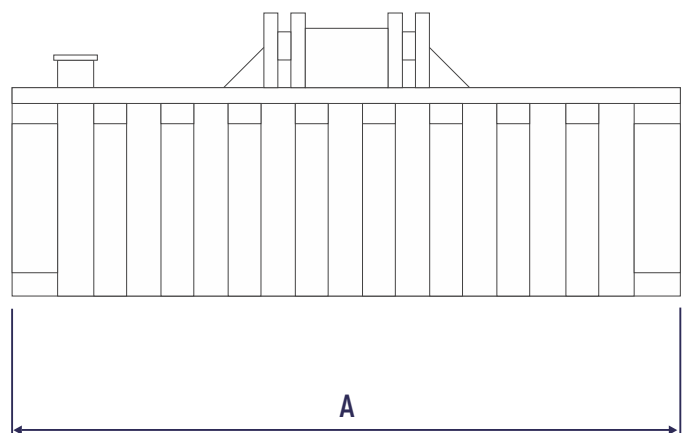

EMGM SERIES (electromagnets for mild slab turning)

Parameters	EMGM 175-77-54/MT-U1	EMGM 240/76-90/AT-U1
Rated voltage, V	220	220
Current, A	60	100
Rated power, W	13200	22000
Pull-off force for flat plate, at least, kg/lbs	50000/110300	100000/220750
Lifting capacity for plate, up to, kg/lbs	25000/55100	50000/110300
Dimensions, mm/in	1780x770x540/70x30x21	2410x770x800/94x30x31
Weight (without straps), kg/lbs	3850/8500	7000/15450
Maximum cargo temperature, °C/°F	500/932	500/932
Protection degree IP	54	54
Ambient temperature, °C/°F	-20...+45/-4...+113	-20...+45/-4...+113

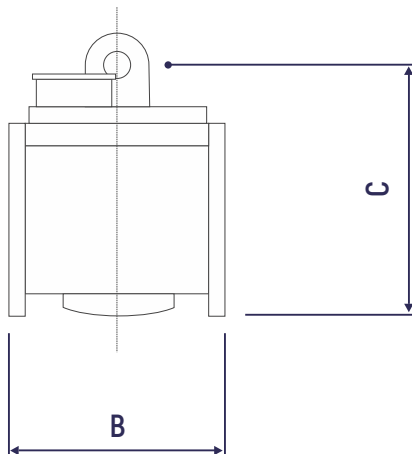

TRANSPORTED CARGO

- Slabs
- Blooms
- Rails

COMPATIBLE EQUIPMENT

- Cranes
- Spreader beams

KEY FEATURES

- Energy saving
- Cargo temperature up to 650 °C/1200 °F

WINDING TYPE

- Aluminium coil

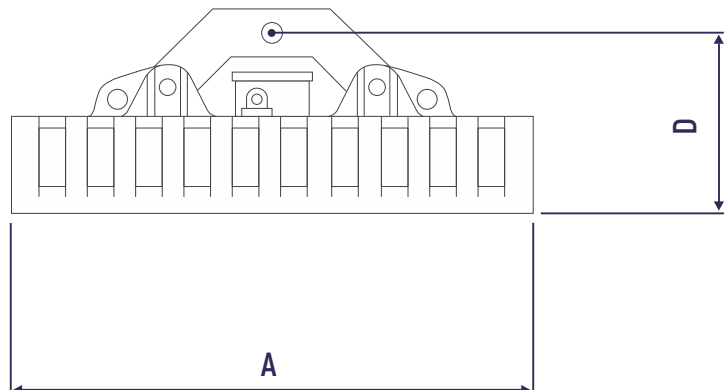

EMG SERIES Rectangular electromagnets (for reloading of blooms, rails, forgings)

Model	Pull-off force kg/lbs, at least	Power with the heated coil, W	Weight, kg/lbs	Rated current, A	Rated power, W	AxBxCxD, mm/in	Lifting capacity, at least, t °C/ °F
							Slabs 600 °C/ 1110 °F
EMG 110-64-42/A-U1	20000/44100	2600	1500/3310	18±8%	4000	1100x640x420x590/43x25x17x26	10000/22000
EMG 170-70-41/A-U1	30000/66100	5200	2000/4400	35±8%	7700	1700x700x410x580/67x28x16x28	15000/33100

HEAT-RESISTANT SERIES OF ELECTROMAGNETS FOR SLABS, BLOOMS AND RAILS

developed in special cast cases with extended poles for superheavy operating mode for high efficiency handling of slabs, forgings, heavyweight metal blanks at steel mills, marine terminals and EPC companies, with the cargo temperature up to 650 °C/1200 °F.

Model	Pull-off force kg/lbs, at least	Power with the heated coil, W	Weight, kg/lbs	Rated current, A	Rated power, W	AxBxCxD, mm/in	Lifting capacity, at least, t °C/ °F		
							200 °C/ 390 °F	400 °C/ 750 °F	600 °C/ 1110 °F
EMG 110-64-ST/AT-U1	28000/61700	2600	1900/4200	18±8%	4000	1100x640x420x590/43x25x17x26	14000/30900	12000/26460	8000/17640
EMG 170-70-ST/AT-U1	43000/94800	4300	2400/5300	30±8%	6600	1700x700x420x590/67x28x16x28	21500/47400	18000/40000	13000/28660

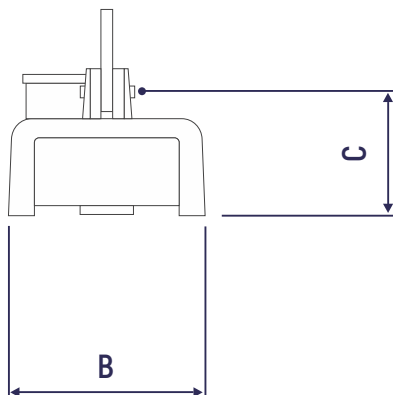

TRANSPORTED CARGO

- Sheet steel in coils
- Rolled vertical coils

COMPATIBLE EQUIPMENT

- Cranes
- Spreader beams

KEY FEATURES

- High reliability and durability of the winding
- High stability of lifting operations
- Special design for operation in underwater conditions as an option
- Heat-resistant version (cargo temperature up to 650 °C/1200 °F) as an option

WINDING TYPE

- Aluminium coil

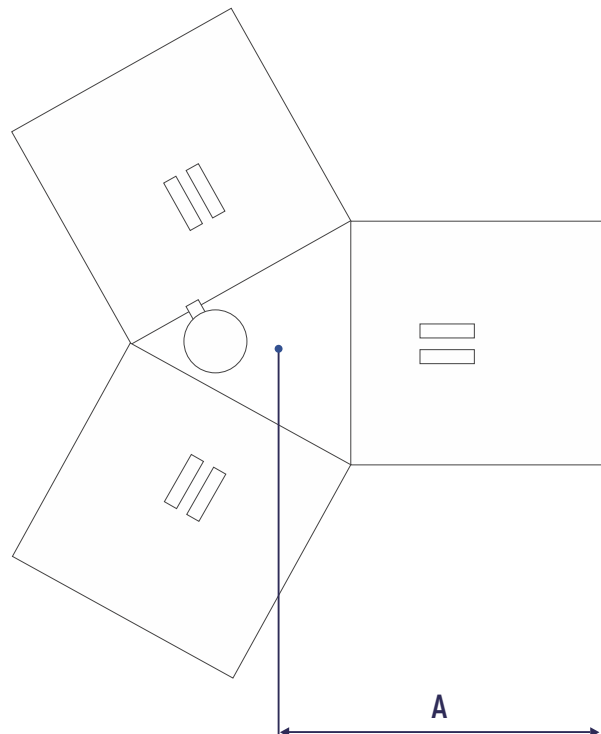

EMGR SERIES (for lifting vertical coils)

Parameters	EMGR 150/A	EMGR 160/A	EMGR 180/A	EMGR 200/A	EMGR 220/A	EMGR 250/A
Rated voltage, V	220	220	220	220	220	220
Rated current at 20 °C/ 70 °F, A	45	60	80	90	90	120
Rated power, W	9900	13200	17600	19800	19800	26400
Steady-state power, W	6400	8400	11500	12900	12900	17200
Maximum coil diameter, mm/in	1500/59	1600/63	1800/70	2000/79	2200/87	2500/98
Lifting capacity for coil, at least, kg/lbs	10000/22050	15000/33100	25000/	32000/70550	36000/79400	42000/93000
Dimensions AxBxC, mm/in	750x420x1500/ 29x16x59	800x460x1600/ 31x18x62	900x500x1700/ 35x19x66	1000x550x1800/ 39x21x70	1080x580x2000/ 42x22x78	1230x580x2100/ 48x22x82
Weight, kg/lbs	2200/4850	3000/6600	4500/9900	5500/12100	6000/13200	7000/15400

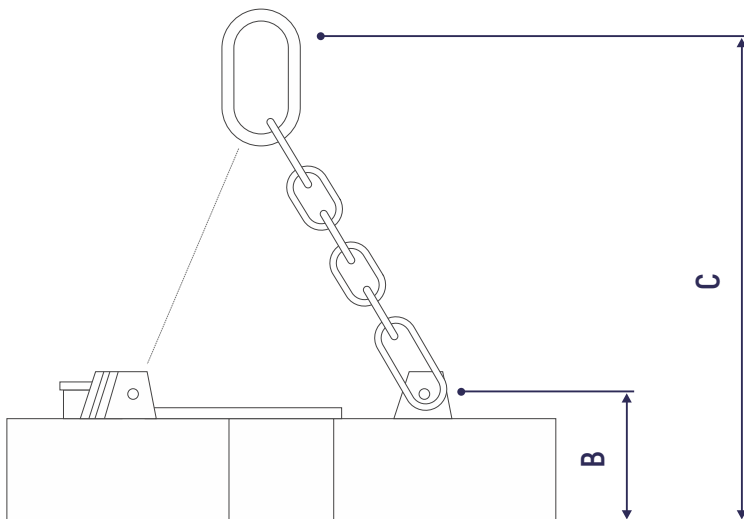

TRANSPORTED CARGO

- Sheet steel in coils, for horizontal coils

COMPATIBLE EQUIPMENT

- Cranes
- Spreader beams

KEY FEATURES

- High reliability and durability of the winding
- High stability of lifting operations
- Special design for use in underwater conditions as an option
- Heat-resistant version (cargo temperature up to 650 °C/1200 °F) as an option

WINDING TYPE

- Aluminium coil

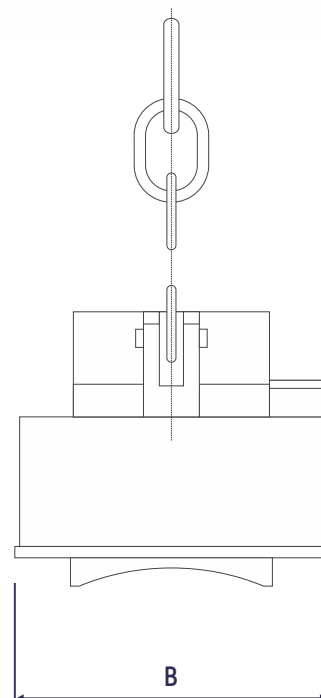

EMGB SERIES (for lifting horizontal coils)

Parameters	EMGB 100-98-60/A-U1	EMGB 116-84-65/A-U1	EMGB 120-98-75/A-U1	EMGB 145-153-85/A-U1
Rated voltage, V	220	220	220	220
Rated current at 20 °C/70 °F, A	45	60	60	80
Rated power, W	9900	13200	13200	17600
Maximum coil diameter, mm/in	1400/55	1600/63	1800/71	2000/79
Lifting capacity for coil, up to, kg/lbs	12000/26500	15000/33070	18000/39700	30000/66140
Dimensions AxBxC, mm/in	1030x980x600/40x38x23	1160x840x650/45x33x25	1200x980x750/47x38x29	1450x1530x850/57x60x33
Electromagnet weight, kg/lbs	2300/5070	2800/6200	3700/8200	8000/17600

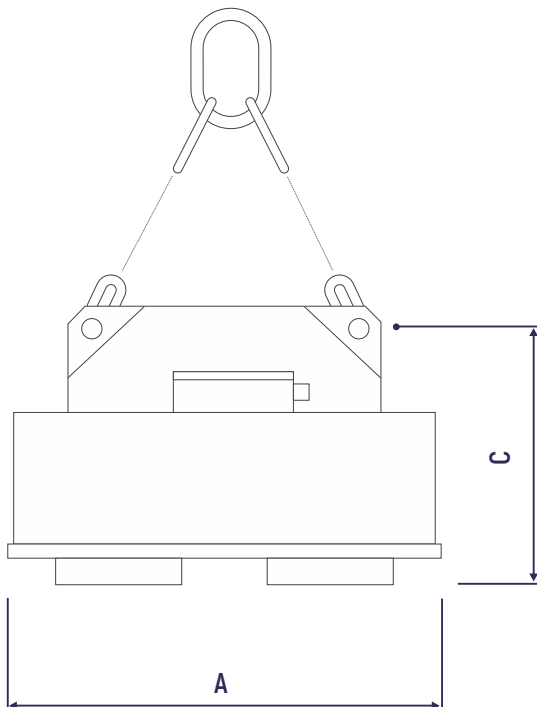

TRANSPORTED CARGO

- Large diameter tubes

COMPATIBLE EQUIPMENT

- Cranes
- Spreader beams

KEY FEATURES

- High reliability and durability of the winding
- High stability of lifting operations
- Special design for use in underwater conditions as an option
- Heat-resistant version (cargo temperature up to 650 °C/1200 °F) as an option

WINDING TYPE

- Aluminium coil

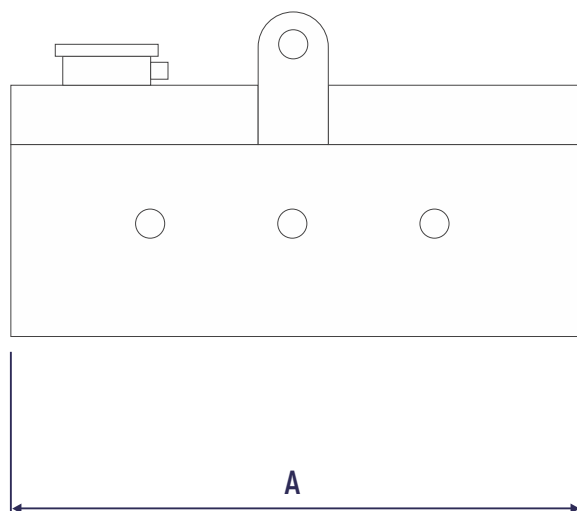

EMGT SERIES (for handling of large diameter tubes)

Parameters	EMGT100/A-U1	EMGT 120/A-U1	EMGT 140/A-U1
Rated voltage, V	220	220	220
Rated current at 20 °C/70 °F, A	22	45	54
Rated power, W	4800	9900	11900
Steady-state power, W	3400	6900	8300
Lifting capacity, kg/lbs	3000/6600	6000/13000	10000/22000
Pipe diameter, mm/in	400-800/15-31	700-1400/27-55	1000-2000/39-78
Dimensions AxBxC, mm/in	1000x310x600/39x12x23	1200x360x620/47x14x24	1400x420x640/55x16x25
Weight, kg/lbs	800/1760	1250/2760	2000/4410

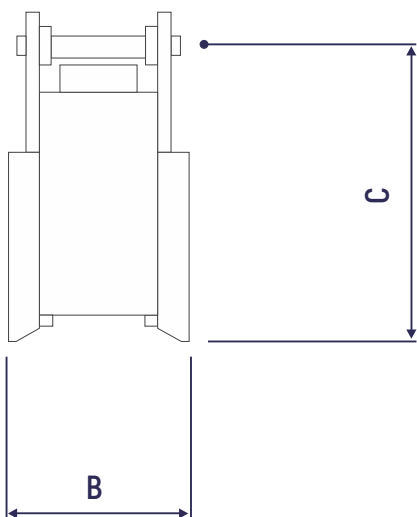

TRANSPORTED CARGO

- Sheet steel in packs or in single pieces
- Slabs

COMPATIBLE EQUIPMENT

- Cranes
- Spreader beams

KEY FEATURES

- The electro-permanent magnet can be switched with pulse without requiring continuous current
- The magnetized cargo hold by the magnet as long as required
- Energy saving
- High safety level
- Easy control
- High level of labor efficiency

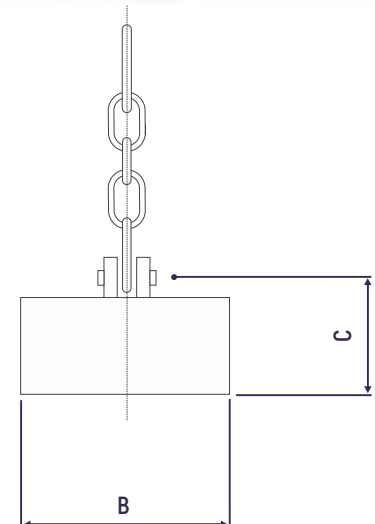
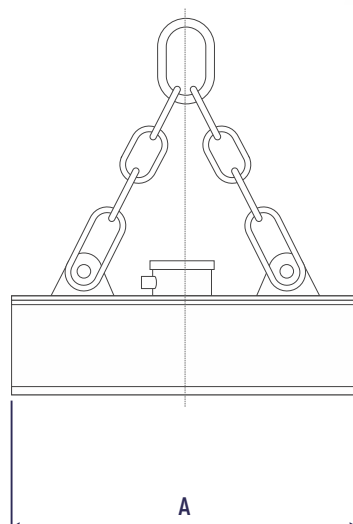

1. IMG SERIES Electropermanent magnets (reloading of sheet steel in packs, slabs)

Parameters	IMG 120-60-32-U1	IMG 130-70-35-U1	IMG 150-76-37-U1
Impulse voltage, V	230	230	230
Impulse current, A	20	32	30
Impulse power, W	4600	7360	6900
Weight, kg/lbs	1200/2645	1850/4080	2300/5070
Pull-off force, kg/lbs	30000/66140	45000/99210	51000/112435
Lifting capacity for plates, kg/lbs	10000/22050	15000/33070	17000/37500
Lifting capacity for square blanks, kg/lbs	6500/14330	10000/22050	11500/25350
Dimensions, mm/in	1200x600x320/47x24x15	1300x700x350/51x27x14	1500x760x370/59x30x14

2. IMGK SERIES Electropermanent magnets (grabbing and reloading of large diameter round blanks)

Parameters	IMGK 160-70-40-U1	IMGK 220-66-40-U1	IMGK 400-66-44-U1
Impulse voltage, V	230	230	230
Impulse current, A	40	65	90
Impulse power, W	9200	15000	20700
Weight, kg/lbs	2200/4850	2750/6062	5600/12345
Pull-off force for circle, kg/lbs	24000/53000	33000/73000	84000/19000
Lifting capacity for circle, kg/lbs	8000/18000	11000/24250	28000/62000
Minimum circle diameter, mm/in	300/12	400/16	400/16
Maximum circle diameter, mm/in	430/17	550/22	600/24
Dimensions, mm/in	1600x700x400/63x27x16	2200x660x400/87x26x16	4000x660x440/157x26x17

3. IMGs SERIES Electropermanent magnets (reloading of sheet steel in single pieces)

Parameters	IMGs 075-25-23-Y1	IMGs 130-37-30-U1	IMGs 180-48-31-U1
Impulse voltage, V	230	230	230
Impulse current, A	10	15	32
Impulse power, W	2300	3500	7400
Weight, kg/lbs	250/551	750/1650	1450/3200
Pull-off force, kg/lbs	7800/17200	19000/42000	40500/89300
Lifting capacity for plates, kg/lbs	2600/5732	6300/14000	13500/29800
Lifting capacity for sheets, kg/lbs	1500/3307	3600/7940	7000/15400
Minimum sheet thickness, mm/in	4/0,15	4,5/0,17	6/0,23
Dimensions, mm/in	750x250x230/29x10x9	1300x370x300/51x14x12	1800x480x310/71x19x12

36 Magnetic beam for square blanks

Application

- Smelters
- Rolled metal warehouses
- Ports
- Machine-building and metalworking enterprises

Compatible equipment

- Cranes
- Loaders

Type of transported cargo

- Square and rectangular blanks



A series of magnetic beams is designed for handling long square blanks, blooms and other types of rolled products of similar geometry. We recommend the use of magnetic beams for handling square and rectangular long loads with specially designed DIMET electromagnets from the EMG and EMGS lines.

PARAMETERS		
Crane capacity	t /lbs	10-50/22050-110231
Load	-	square blank
Load temperature	°C/°F	-40 to +650/-40 to +284
Blank length	mm/in	2000 to 18000/79 to 710
Blank dimensions (min/max)	mm/in	120x120 to 180x180/5x5 to 7x7
Blank weight (min/max)	kg/in	1000 to 4000/39 to 160
Load weight	kg/in	up to 20000/up to 44100
Ambient temperature	°C/°F	-40 to +60/-40...+140
No. of blanks reloaded per single lift	ea	1-10

Application

- Smelters
- Rolled metal warehouses
- Ports
- Machine-building and metalworking enterprises
- Construction companies and manufacturers of construction materials

Compatible equipment

- Cranes
- Loaders

Transported cargo

- Round blanks



DIMET magnetic beams for bundles of rebars and round blanks are used in permanent production lines and can be suspended using straps on mobile cranes and loaders. Our technical solutions include extendable beams with an adjustable distance between electromagnets. They facilitate movement of loads with various linear dimensions. Beams can be equipped with a voltage converter, an uninterrupted power supply, or a cable reel. We have also developed models with additional grips (in addition to electromagnets). It is recommended to use magnetic beams with specially designed DIMET electromagnets from EMG and EMGS lines.

PARAMETERS		
Crane capacity	t/lbs	10-50/22050-110231
Load	-	round blanks
Load temperature	°C/°F	-40 to +650/-40 to +284
Blank length	mm/in	2000 to 18000/79 to 710
Blank dimensions (min/max)	mm/ in	200 to 600/8 to 24
Load weight	kg/lbs	up to 35000/up to 77200
Ambient temperature	°C/°F	-40 to +60/-40...+140
No. of blanks reloaded per single lift	ea	1-14

Application

- Smelters
- Rolled metal warehouses
- Ports
- Machine-building and metalworking enterprises
- Construction companies and manufacturers of construction materials

Compatible equipment

- Cranes
- Loaders

Transported cargo

- Wire coils



DIMET magnetic beams for handling rebars and rolled wire make it possible to simultaneously handle several bundles of rebars, rolled wire, and circle. This significantly improves the rate of handling these loads and allows for optimal use of the crane lifting capacity. Beams for bundle handling can be also equipped with voltage converters, uninterrupted power supplies and cable reels from our company. It is most efficient to use these beams with DIMET EMGK electromagnets specially designed for bundle lifting and handling.

PARAMETERS

Crane capacity	t/lbs	10-25/394-984
Loads	-	Bundles of rebars, rolled wire
Load temperature (min/max)	°C/°F	-40 to +500/-40 to +932
Bundle diameter (min/max)	mm/in	800 to 1550/31 to 61
Maximum bundle height	mm/in	up to 2600/up to 102
Load weight	kg/lbs	up to 10000/up to 394
Bundle weight (min/max)	kg/lbs	1000 to 4000/39 to 160
Ambient temperature	°C/°F	-40 to +60/-40...+140
No. of packs (bundles) reloaded per single lift	ea	1-5

Application

- Smelters
- Rolled metal warehouse
- Ports
- Machine-building and metalworking enterprises
- Construction companies and manufacturers of construction materials



Compatible equipment

- Cranes
- Loaders

Transported cargo

- Handling of long loads
- Handling pipes, slabs, sheet steel in packs or piece by piece
- Removing sheets from plasma cutting machines



Special series of DIMET magnetic beams for handling long loads.

PARAMETERS		
Crane capacity	t/lbs	5-63/11023-13900
Load	-	Single piece sheets, sheet packs
Load temperature (min/max)	°C/°F	-40...+650/-40...+1202
Load length (min/max)	mm/in	2000...12000/79...472
Load width (min/max)	mm/in	1000...4500/39...180
Sheet thickness	mm/in	1...120/0,03...5
Pack thickness	mm/in	50...400/2...16
Load weight	mm/in	up to 25000/up to 984
Ambient temperature	°C/°F	-40...+60/-40...+140
Crane capacity	t/lbs	10-50/22050-110231
Load	-	Round blanks
Load temperature (min/max)	°C/°F	-40...+500/-40...+932
Load length (min/max)	mm/in	2000...12000/79...472
Blank dimensions (min/max)	mm/in	200...600/8...24
Load weight	mm/in	up to 35000/up to 1380
Ambient temperature	°C/°F	-40...+60/-40...+140

40 Magnetic beam for handling slabs

Application

- Smelters
- Warehouses and transportation facilities where slabs are reloaded and stored

Compatible equipment

- Cranes
- Loaders

Transported cargo

- Hot and cold slabs



DIMET beams for handling slabs can handle both hot and cold slabs. They greatly save factory's resources and improve personnel safety. Using electromagnets when handling slabs prevents direct contact of workers with the load and makes it possible to increase the capacity of warehouse thanks to minimized gaps between piles when stored. Magnetic beams for handling slabs are made as per individual requirements and can be equipped with voltage converters, uninterrupted power supplies, or cable reels manufactured by our company. Therefore, they can be easily integrated into production lines and logistic chains of smelters. DIMET magnetic beams are recommended to be used together with electrical and electropermanent DIMET magnets from EMGS, ING, EMG lines.

PARAMETERS

Crane capacity	t/lbs	20-80/4410-17640
Load	-	Slab
Load temperature (min/max)	°C/°F	-40...+650/-40...+1202
Load length (min/max)	mm/in	3000...12000/118...472
Load width (min/max)	mm/in	500...3200/19...126
Load weight	kg/lbs	up to 60000/up to 132300
Slab width (min/max)	mm/in	100...450/4...18
Ambient temperature	°C/°F	-40...+60/-40...+140

APPLICATION

- Steelmaking and rolling shops at smelters

COMPATIBLE EQUIPMENT

- Cranes
- Loaders

TRANSPORTED CARGO

- Hot and cold slabs



DIMET magnetic beams for mild slab turning are developed together with DIMET EMGM electromagnets in order to improve efficiency and safety when handling slabs at production lines of smelters

This solution allows:

- increasing the turning speed
- removing personnel from the area where hot slabs are turned

APPLICATION

- Ferrous and non-ferrous metal industry

COMPATIBLE EQUIPMENT

- Cranes



DIMET spatial beam for handling mill rolls consist of a welded housing with side plates for cargo suspension, which rotate around the axis. Depending on the crane capacity, the beam can be equipped with a suspension for a single or double hook.

APPLICATION

- Smelters
- Factories manufacturing pipes, rebars, shapes
- Rolled steel warehouses
- Ports
- Machine-building and metal-working plants

COMPATIBLE EQUIPMENT

- Cranes



DIMET hook linear beams are used for handling various long loads when the lifting height is restricted. The beam design may include reversible cages or extendable cantilevers used to adjust the distance between cargo attachment points. This design is used when it is required to handle cargoes of various length. Depending on the type, we equip beams with various grips:

- Eye (one or two)
- Pulley block
- Sling chain

44 DIMET DS 4- and 5-tine grapples

PROPERTIES

- Capacity up to 1000 liters
- Weight up to 1750 kg/3860 lbs
- Lifting capacity up to 12 tons/2650 lbs
- Permissible load on the support assembly 15 tons/33100 lbs
- System operating pressure up to 300 bar

COMPATIBILITY

- Hydraulic crane trucks
- Hydraulic manipulators
- Hydraulic fixed cranes
- Hydraulic excavators
- Wheel loaders



OPEN TYPE GRAPPLE (O)

for large scrap, shavings, stones or concrete blocks

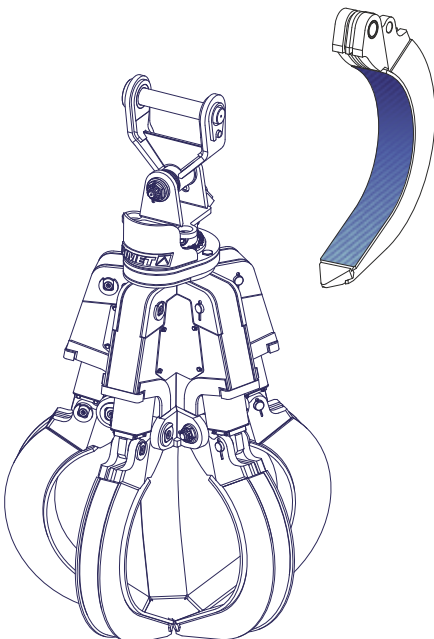

HALF-OPEN TYPE GRAPPLE (HO)

for scrap metal of household items: automobile radiators, batteries, wires and cables, household appliances, engine consoles, etc.

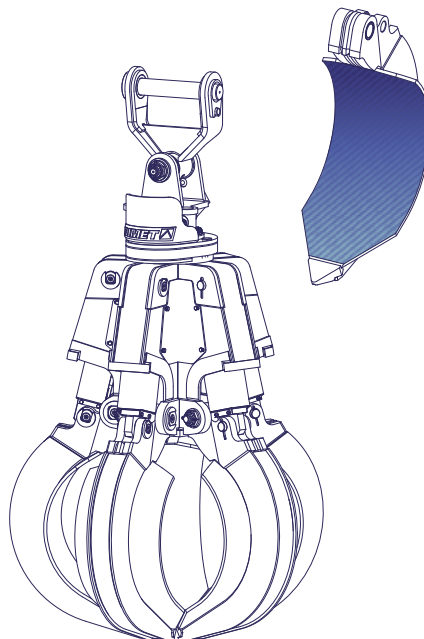

CLOSED TYPE GRAPPLE (O)

for handling of fine fraction scrap

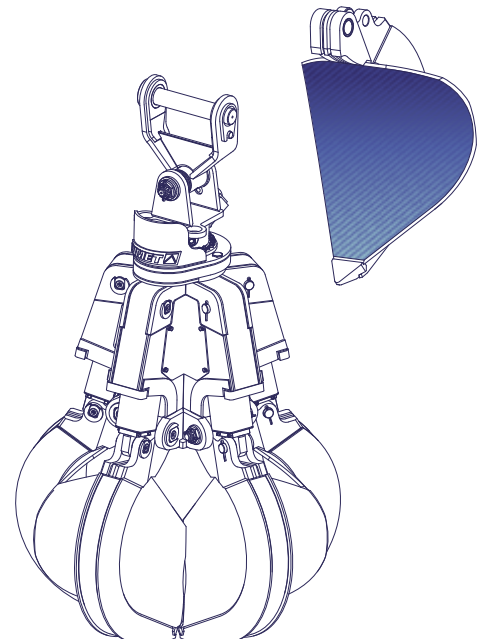

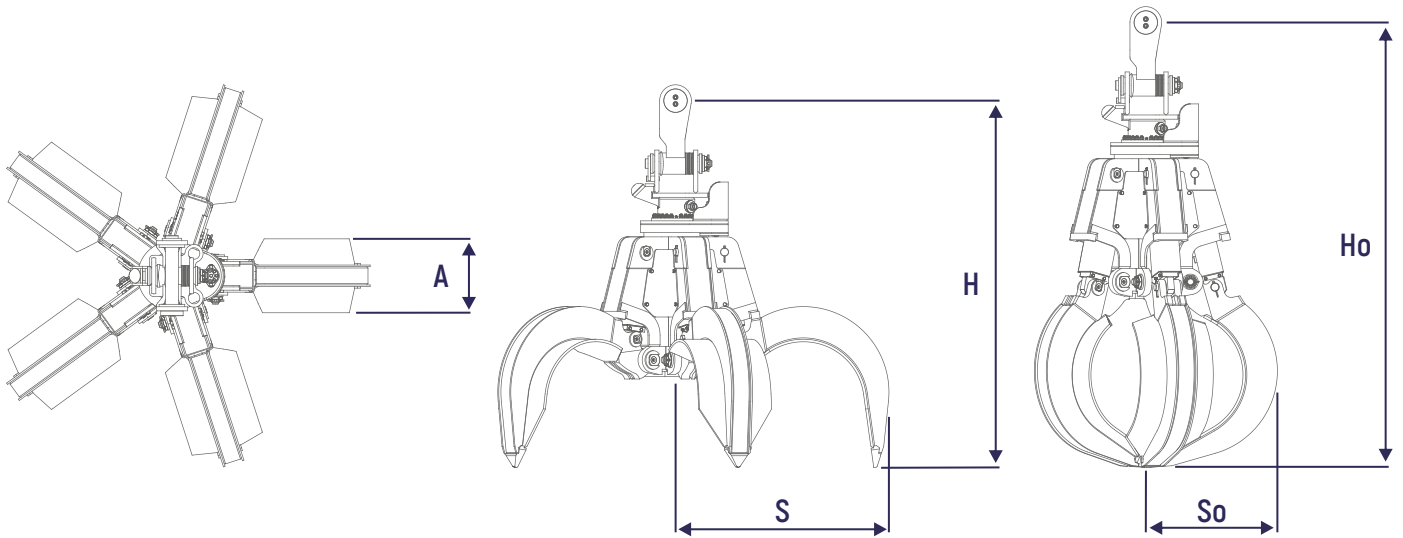

Model	Rotator lifting capacity, kN	Number of tines, pcs	Weight, kg/lbs	Tine width A, mm/in	Height in open position H, mm/in	Height in closed position Ho, mm/in	Width in open position S, mm/in	Width in closed position So, mm/in	Volume, m ³	
DS500A-O	15	5	1390/3060	175/6	2120/83	2500/98	1140/45	700/27	0,5	
DS500A-HO			1580/3500	450/17						
DS500A-C			1680/3700	780/30						
DS500A-4-O		4	1300/2900	175/6						
DS500A-4-HO			1380/3040	450/17						
DS500A-4-C			1540/3400	1070/42						
DS600L-O		5	5	1460/3220	175/6	2125/84	2550/100	1200/47	725/28	0,6
DS600L-HO				1600/3530	450/17					
DS600L-C				1700/3750	800/31					
DS600L-4-O			4	1260/2800	175/6					
DS600L-4-HO				1400/3100	450/17					
DS600L-4-C				1570/3500	1160/45					
DS800L-O		5	5	1480/3300	175/6	2175/85	2640/104	1260/49	775/30	0,8
DS800L-HO				1670/3700	450/17					
DS800L-C				1760/3900	835/32					
DS800L-4-O			4	1360/3000	175/6					
DS800L-4-HO				1450/3200	450/17					
DS800L-4-C				1620/3600	1245/49					
DS1000L-4-O		5	5	1440/3200	175/6	2220/87	2800/110	1370/54	820/32	1,0
DS1000L-4-HO				1520/3350	450/17					
DS1000L-O	1550/3420			175/6						
DS1000L-HO	1750/3860		450/17							
DS1000L-C	1960/4320		880/34							

PROPERTIES

- Capacity up to 1000 liters
- Weight up to 1750 kg/3860 lbs
- Lifting capacity up to 12 tons/2650 lbs
- Permissible load on the support assembly 15 tons/33100 lbs
- System operating pressure up to 300 bar

COMPATIBILITY

- Hydraulic crane trucks
- Hydraulic manipulators
- Hydraulic fixed cranes
- Hydraulic excavators
- Wheel-mounted loaders



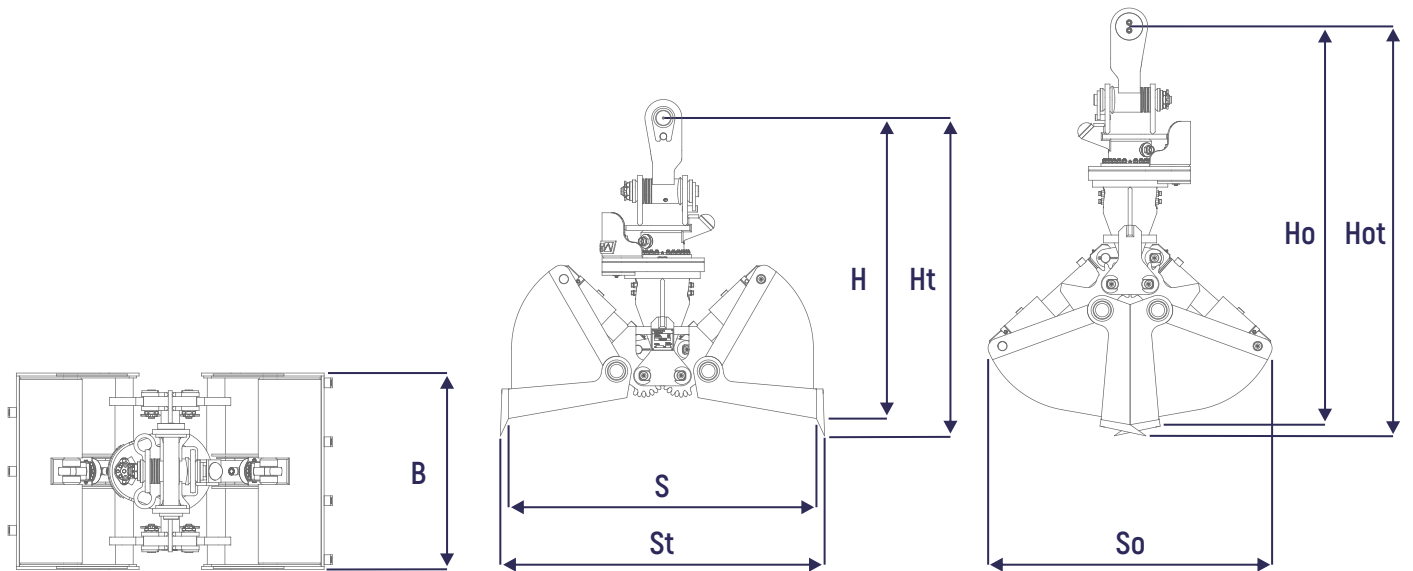

Designation	Load capacity of the rotator, t/lbs	Type (the analogue)*	Dimensions. Mass without teeth, kg/lbs	Broad B, mm/in	Height when unfolded with teeth/without teeth Ht/H, mm/in	Height when folded with teeth/without teeth Hot/Ho, mm/in	Length when unfolded with teeth/without teeth St/S, mm/in	Length when folded So, mm/in	Number of hydraulic cylinders, pieces	Volume, m ³
DSB500H	15/33700	E346	950. 930/2100. 2050	800/31	1620/1530 63/60	2085/2025 82/79	1650/1570 64/61	1450/57	2	0,5
DSB630H		E348	990. 970/2200. 2140	1000/39						0,63
DSB800A		SGZ800.20	1050. 1030/2300. 2270	1250/49						0,8
DSB1000L		SGZ1000.20	1100. 1080/2400. 2380	1000/39	1660/1575	2335/2280	2140/2060	1470/57	4	1,0
DSB1000H		SGZ1000.40	1230. 1210/2700. 2670	1000/39						1,0
DSB1250A		E75.32	1300. 1280/2900. 2870	1250/49	65/62	91/89	84/81			1,25
DSB1500L		E75.33	1370. 1340/3020. 2950	1500/59						1,5

* the term "analogue" means a product that is similar in its characteristics. There may be insignificant differences in sizes and characteristics from the listed analogue.

Four rope grapples are used in cranes equipped with two mechanisms: one for closing ropes, the other for supporting ropes

Key features

- Grapple design (tie-rods, beams, tines) is reinforced
- To facilitate maintenance, grapple tie rods have steps
- Bucket opening synchronizer gears are located in a closed case of the lower beam, which prevents the contact of toothed gearing with the reloaded material
- Block baskets of the tackle are removable

As optionally agreed

- Various design options of grapple suspension (supporting block, balance-beams, eyes with wedge bushes)
- Longitudinal tine opening
- Blades made of high strength wear resistant steel Hardox Teeth installed on the bucket (for hard to grapple or lump cargoes)
- Can operate in water (underwater scooping)



Motorized grapples are removable mechanisms (suspended on the hook)

Key features

- An imported tackle is used as a mechanism closing the grapple, which has a capacity limiter and a rope layer
- To facilitate maintenance, grapple tie rods have steps

As optionally agreed

- Blades made of high strength wear resistant steel Hardox
- Teeth installed on the bucket (for hard to grapple or lump cargoes)



Application

- Removal and extraction of tramp iron and items made of loose materials

Compatible equipment

- Belt conveyor

Key features

- Compactness
- Mobility
- Low power consumption
- Easy installation

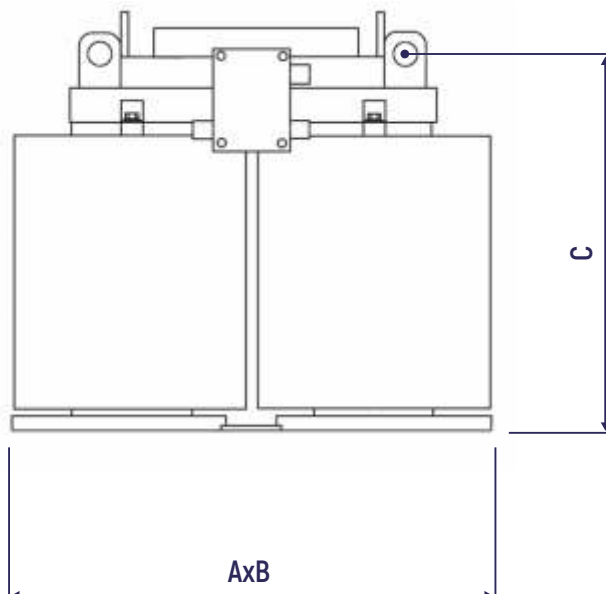
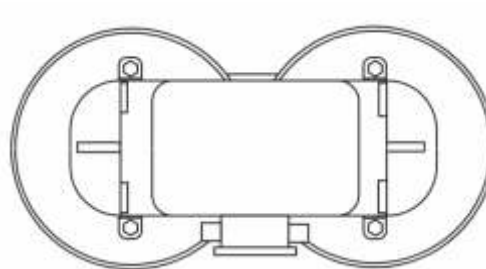
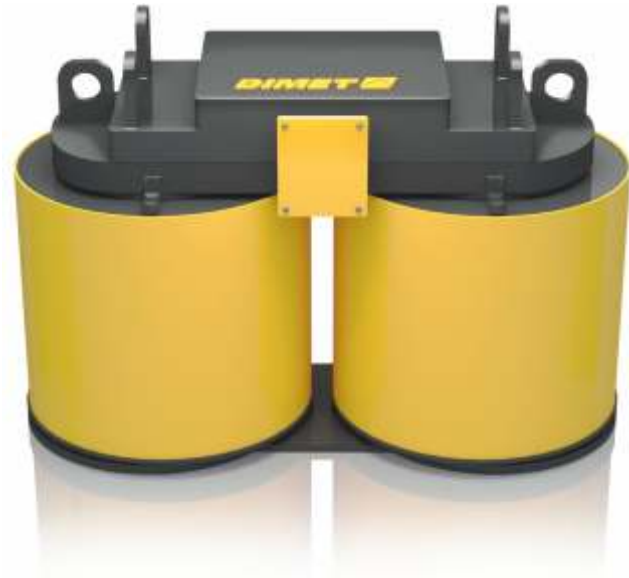

Model	Dimensions AxBxC, mm/in	Rated winding current at 20 °C/70 °F, A	Power at steady-state temperature, W	Conveyor belt width, mm/in	Weight of extracted scrap, kg/lbs	Extraction zone depth, mm/in	Weight, kg/lbs
EMZ 065/25	680x430x620/26x16x24	10	1400	650/25	0,01-10/0,02-22	250/9	600/1320
EMZ 065/35	680x430x780/26x16x30	14	2000	650/25	0,01-10/0,02-22	350/13	770/1700
EMZ 080/30	800x450x680/31x17x26	14	2000	800/31	0,01-15/0,02-33	300/11	850/1900
EMZ 080/40	800x480x780/26x18x30	17	2400	800/31	0,01-15/0,02-33	400/15	1050/2300
EMZ 100/35	1020x500x760/40x19x29	17	2400	1000/39	0,01-20/0,02-44	350/13	1300/2900
EMZ 100/45	1020x520x780/40x20x30	20	2900	1000/39	0,01-20/0,02-44	450/17	1400/3100
EMZ 120/40	1150x570x710/45x22x27	20	2900	1200/47	0,01-25/0,02-55	400/15	1650/3640
EMZ 120/55	1240x620x790/48x24x31	28	4000	1200/47	0,01-25/0,02-55	550/21	2200/4850
EMZ 140/45	1300x580x850/51x22x33	24	3400	1400/55	0,01-25/0,02-55	450/17	2100/4630
EMZ 140/60	1300x620x1020/51x24x40	37	5300	1400/55	0,01-25/0,02-55	600/23	2700/5950
EMZ 160/45	1500x640x880/59x25x34	28	4000	1600/62	0,01-30/0,02-66	450/17	2500/5500
EMZ 160/60	1500x720x980/59x28x38	42	6000	1600/62	0,01-30/0,02-66	600/23	3700/8160
EMZ 180/45	1700x640x1020/66x25x40	37	5300	1800/70	0,01-35/0,02-77	450/17	3300/7300
EMZ 180/60	1700x680x1200/66x26x40	42	6000	1800/70	0,01-35/0,02-77	600/23	4000/8820
EMZ 200/45	1900x900x930/74x35x36	42	6000	2000/78	0,01-35/0,02-77	450/17	4800/10600
EMZ 200/60	1900x900x1000/74x35x39	55	8000	2000/78	0,01-35/0,02-77	600/23	6500/14330

Principle of operation

- ▲ Tramp iron
- Loose material

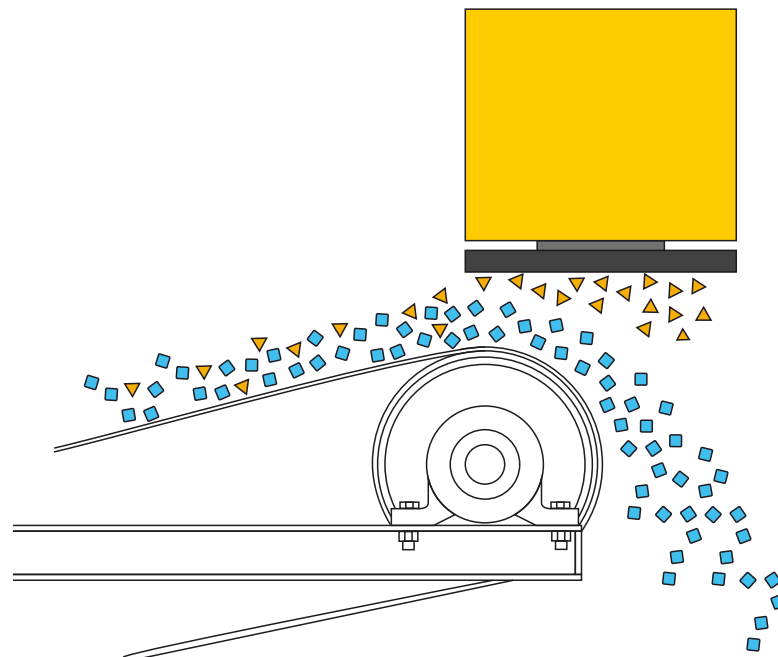

Application

- Removal and extraction of tramp iron and items made of loose materials

Compatible equipment

- Belt conveyor

Key features

- Mobility
- Requires no additional cooling
- Low power consumption
- Long-term continuous operation
- Easy installation

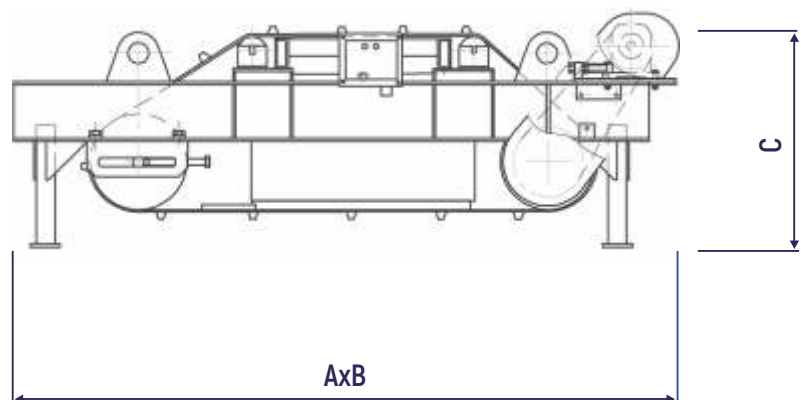
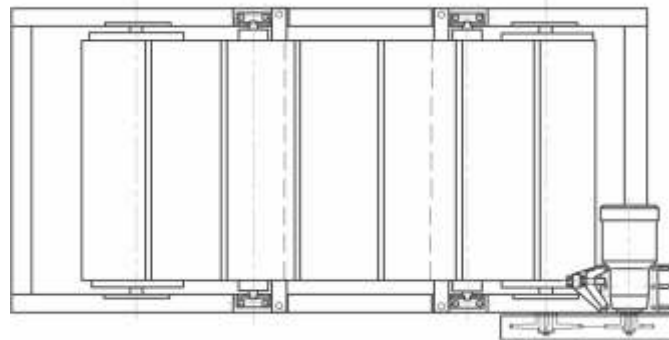

Model	Dimensions AxBxC, mm/in	Rated winding current at 20 °C/70 °F, A	Power at steady-state temperature, W	Conveyor belt width, mm/in	Weight of extracted scrap, kg/lbs	Extraction zone depth, mm/in	Weight, kg/lbs
EMZS 065/25	2020x1225x750/79x48x29	12	1700	650/25	0,01-15/0,02-33	250/9	1580/3500
EMZS 065/35	2020x1225x780/79x48x30	14	2000	650/25	0,01-15/0,02-33	350/13	1740/3840
EMZS 080/25	2140x1225x680/84x48x26	14	2000	800/31	0,01-15/0,02-33	250/9	1750/3900
EMZS 080/35	2140x1225x700/84x48x27	17	2400	800/31	0,01-15/0,02-33	350/13	1900/4200
EMZS 100/30	2250x1550x640/88x61x25	18	2600	1000/39	0,01-20/0,02-44	300/11	2200/4850
EMZS 100/40	2460x1370x620/96x53x24	27	3900	1000/39	0,01-20/0,02-44	400/15	2400/5300
EMZS 120/40	2470x1580x680/97x62x26	34	4900	1200/47	0,01-30/0,02-66	400/15	3200/7050
EMZS 120/55	2520x1150x710/99x45x27	36	5100	1200/47	0,01-30/0,02-66	550/21	3900/8600
EMZS 140/40	2680x1580x620/105x62x24	27	3900	1400/55	0,01-35/0,02-77	400/15	2900/6400
EMZS 140/50	2680x1580x680/105x62x26	34	4900	1400/55	0,01-35/0,02-77	500/19	3900/8600
EMZS 140/60	2680x1580x750/105x62x29	36	5100	1400/55	0,01-35/0,02-77	600/23	4500/9900
EMZS 160/40	2900x1580x800/114x62x31	34	4900	1600/62	0,01-35/0,02-77	400/15	4000/8800
EMZS 160/50	2900x1580x950/114x62x37	36	5100	1600/62	0,01-35/0,02-77	500/19	4500/9900
EMZS 160/60	2900x1580x1010/114x62x39	38	5400	1600/62	0,01-35/0,02-77	600/23	5300/11700
EMZS 180/40	3100x1580x920/122x62x36	34	4900	1800/70	0,01-40/0,02-88	400/15	4800/10600
EMZS 180/50	3100x1580x1010/122x62x39	38	5400	1800/70	0,01-40/0,02-88	500/19	5700/12600
EMZS 180/60	3100x1580x1200/122x62x47	45	6400	1800/70	0,01-40/0,02-88	600/23	6400/14110
EMZS 200/40	3250x1580x920/127x62x36	38	5400	2000/78	0,01-40/0,02-88	400/14	6000/13200
EMZS 200/50	3250x1580x1100/127x62x39	42	6000	2000/78	0,01-40/0,02-88	500/19	6900/15200
EMZS 200/60	3250x1580x1200/127x62x47	47	6700	2000/78	0,01-40/0,02-88	600/23	7800/17200

Principle of operation

- ▲ Tramp iron
- Loose material



APPLICATION

- Power supply and control of lifting direct current electromagnets of any power, and simultaneous supply of several electromagnets, the total current of which does not exceed the permissible values. The types of the supplied electromagnets: all DIMET electromagnets, as well as electromagnets of any other manufacturers



COMPATIBLE EQUIPMENT

- Electromagnets
- Cranes

MAIN TYPES OF PROTECTION

- Limitation of the maximum output voltage at the level of 220-230 V
- Protection from short circuit under load
- Protection from core-to-core fault and earth fault
- Feeding cable breakdown alarm
- Alarm of surface-leakage current excess in the electromagnet circuit (in case of electromagnet overheating)
- Alarm of occurrence of interturn short circuits in the electromagnet
- Alarm of excess of the maximum permissible current

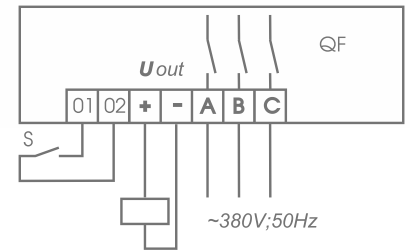

Available as an option

Parameters	PN-500-3-100A	PN-500-3-150A	PN-500-3-200A	PN-500-3-250A
Power supply	three-phase	three-phase	three-phase	three-phase
Supply voltage, V	380±60	380±60	380±60	380±60
Frequency, Hz	50	50	50	50
Output voltage regulation range, V	10-230	10-230	60-230	60-230
Demagnetizing time, at most, s	3	3	5	5
Duty cycle, %	75, 100	75, 100	75, 100	75, 100
Maximum permissible current at duty cycle - 75%, A	100	150	200	250
Maximum permissible current at duty cycle - 100%, A	50	80	110	125
Overall dimensions, mm/in	500x385x200/20x15x8	500x385x200/20x15x8	600x505x250/24x20x10	600x505x250/24x20x10
Coupling sizes, mm/in	255x360/10x14	255x360/10x14	380x480/15x19	380x480/15x19
Weight, at most, kg/lbs	20/44	20/44	32/70	33/70

APPLICATION

- Standby power supply for electromagnet

MAJOR TASKS

- Provision of operation safety, prevention from emergency cargo release after supply voltage blackout
- Control of voltage supply on all the three network phases
- Alarm of disappearance of the main supply and switch of the electromagnet operation to standby power supply from batteries
- Connected parallel to electromagnet

KEY FEATURES

- Convenience of operation: application of unattended accumulators (service life up to 10 years) in the circuit of uninterrupted power supply, status monitoring of each battery, automatic battery recharge
- Limitation of the maximum output voltage at the level of $220+5\% V$, which prevents from electromagnet breakdown
- Alphanumeric display of the current parameters, working modes and emergency shutoffs, audio alarm of emergency situations secures the convenience of operation of this equipment



Parameters	IBPN-500-100A	IBPN-500-150A	IBPN-500-200A	IBPN-500-250A
Power supply	three-phase	three-phase	three-phase	three-phase
Voltage supply, V	380 \pm 60	380 \pm 60	380 \pm 60	380 \pm 60
Frequency, Hz	50	50	50	50
Permanent output voltage, V	220 \pm 5%	220 \pm 5%	220 \pm 5%	220 \pm 5%
Battery operation at least, min	15	15	15	15
Max. permissible current, A	100	150	200	250
Overall dimensions at most, mm/in	1595x1020x640/62x40x25	1595x1020x640/62x40x25	1320x1805x580/51x71x22	1320x1805x580/51x71x22
Weight at most, kg/lbs	410/904	430/950	640/1410	660/1460

APPLICATION

- Operation with generators, installed on the crane facilities and scrap handlers when the fixed network is absent. Intended for supply and control of lifting direct current electromagnets of any power and for combined operation with generators of 220 or 380 V. Types of the supplied electromagnets: all the DIMET electromagnets, as well as electromagnets of any other manufacturers



COMPATIBLE EQUIPMENT

- Electromagnets
- Cranes
- Scrap handlers

MAIN TYPES OF PROTECTION

- Limitation of the maximum output voltage at the level of 220-230 V
- Protection from short circuit under load
- Protection from core-to-core fault and earth fault
- Feeding cable breakdown alarm
- Alarm of surface-leakage current excess in the electromagnet circuit (in case of electromagnet overheating)
- Alarm of occurrence of interturn short circuits in the electromagnet
- Alarm of excess of the maximum permissible current

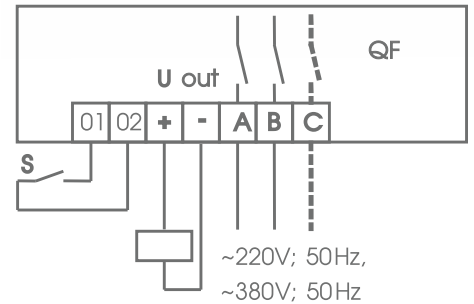

Parameters	PN-500-G-50A	PN-500-G-100A	PN-500-G-150A
Power supply	generator	generator	generator
Voltage supply, V	220/380±60	220/380±60	220/380±60
Frequency, Hz	50	50	50
Control range of output voltage, V	10-230	10-230	10-230
Demagnetization time, max, sec	3	3	3
Maximum allowable current at DC-75%, A	50	100	150
Dimensions, mm/in	360x150x375/14x5x14	360x150x375/14x5x14	360x150x375/14x5x14
Coupling size, mm/in	255x350/10x13	255x350/10x13	255x350/10x13
Weight at most, kg/lbs	12/26	12,2/26	12,5/27





dimetm.com

DIMET GmbH

 Dirnismaning 38, 85748 Garching, Germany

 +49-17-265 992 44

 info@dimetm.com

DIMET USA INC.

 541 Jefferson avenue, suite 100 Redwood City 94063 USA

 +1-903-650-8336

 info@dimetm.com